

FIG. 1

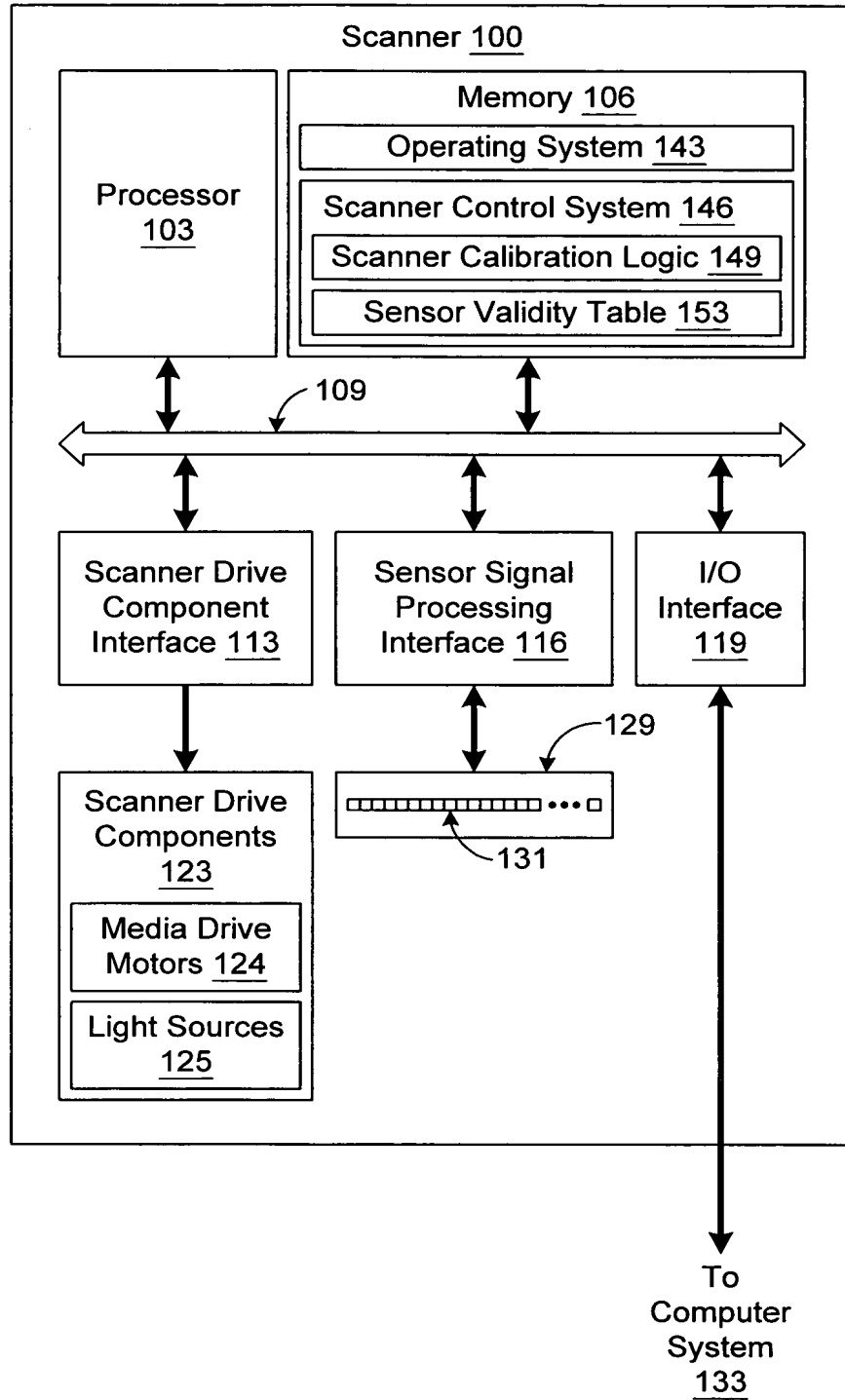

FIG. 1

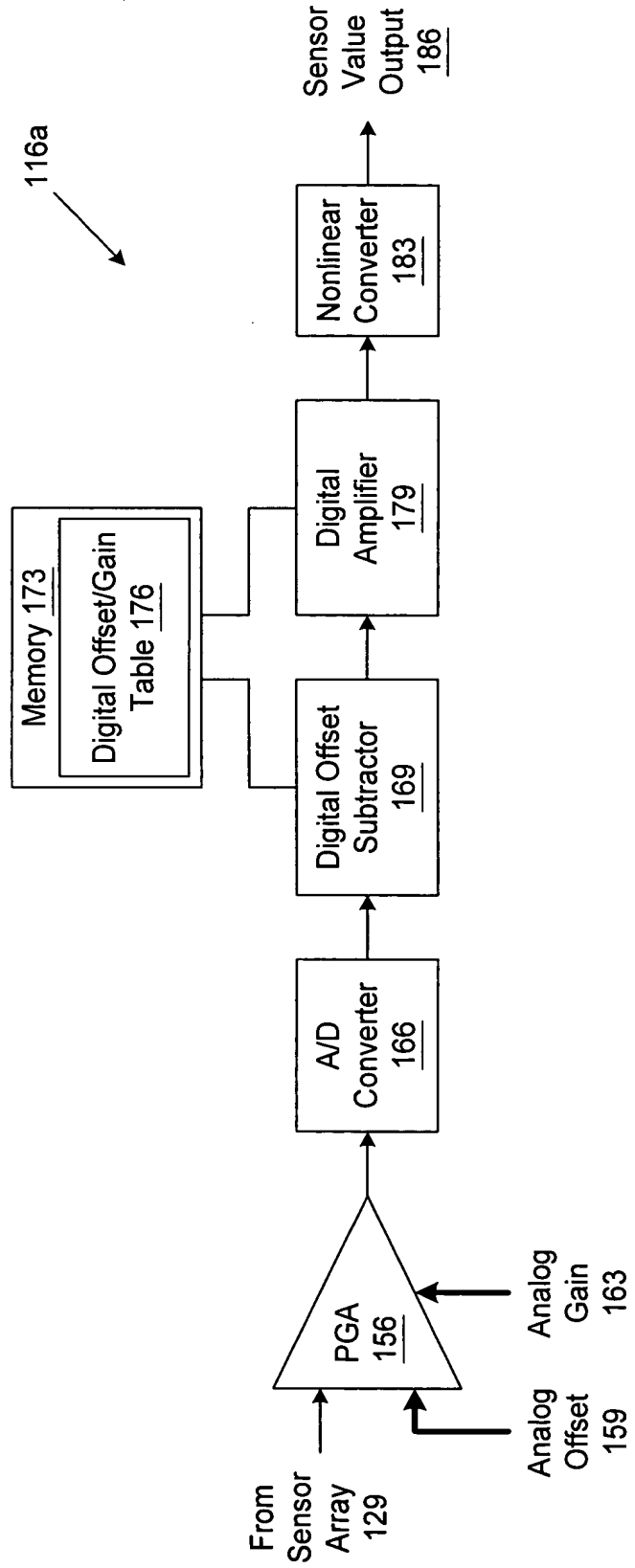

FIG. 2

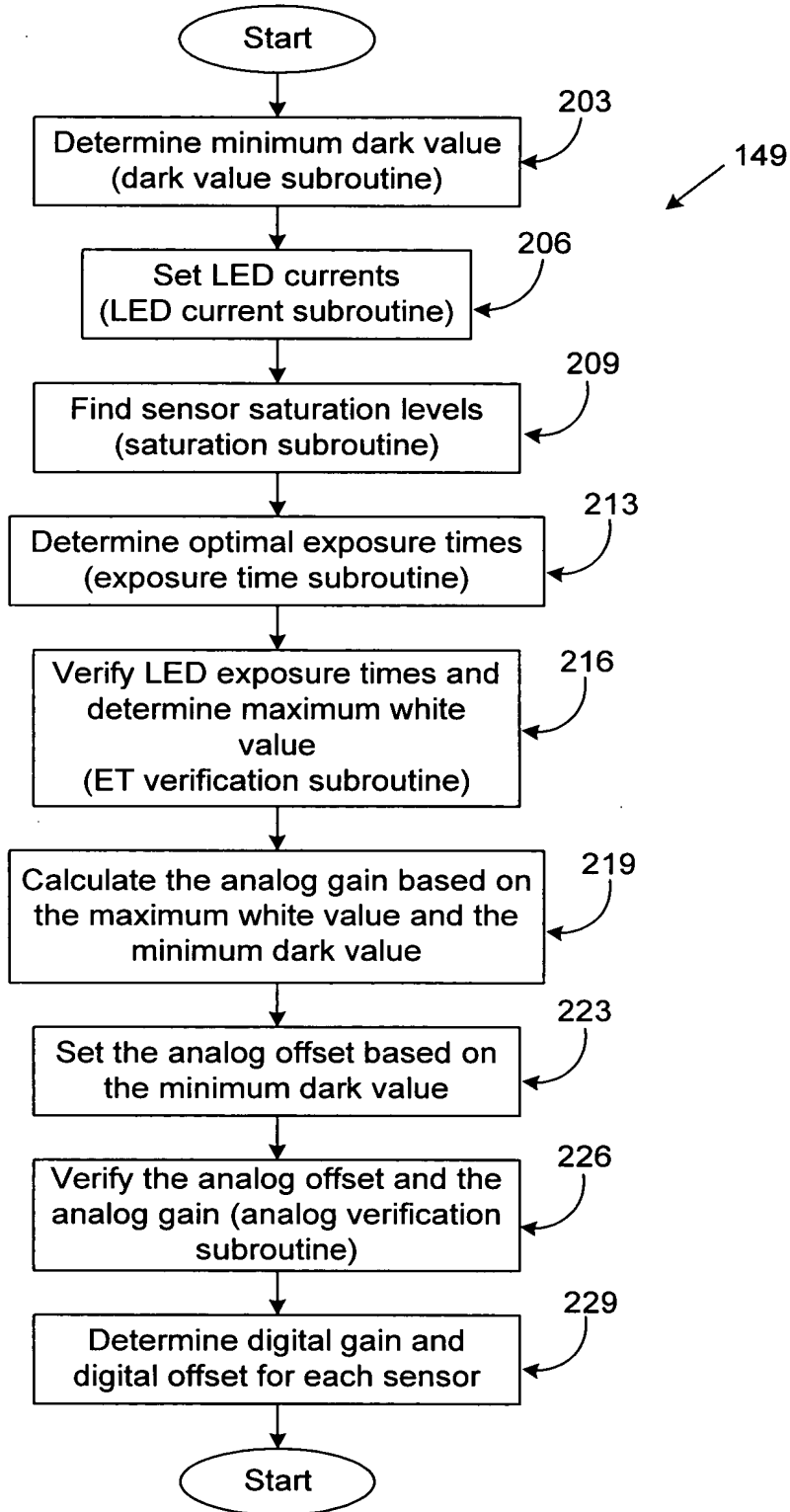

FIG. 3

TOP SECRET

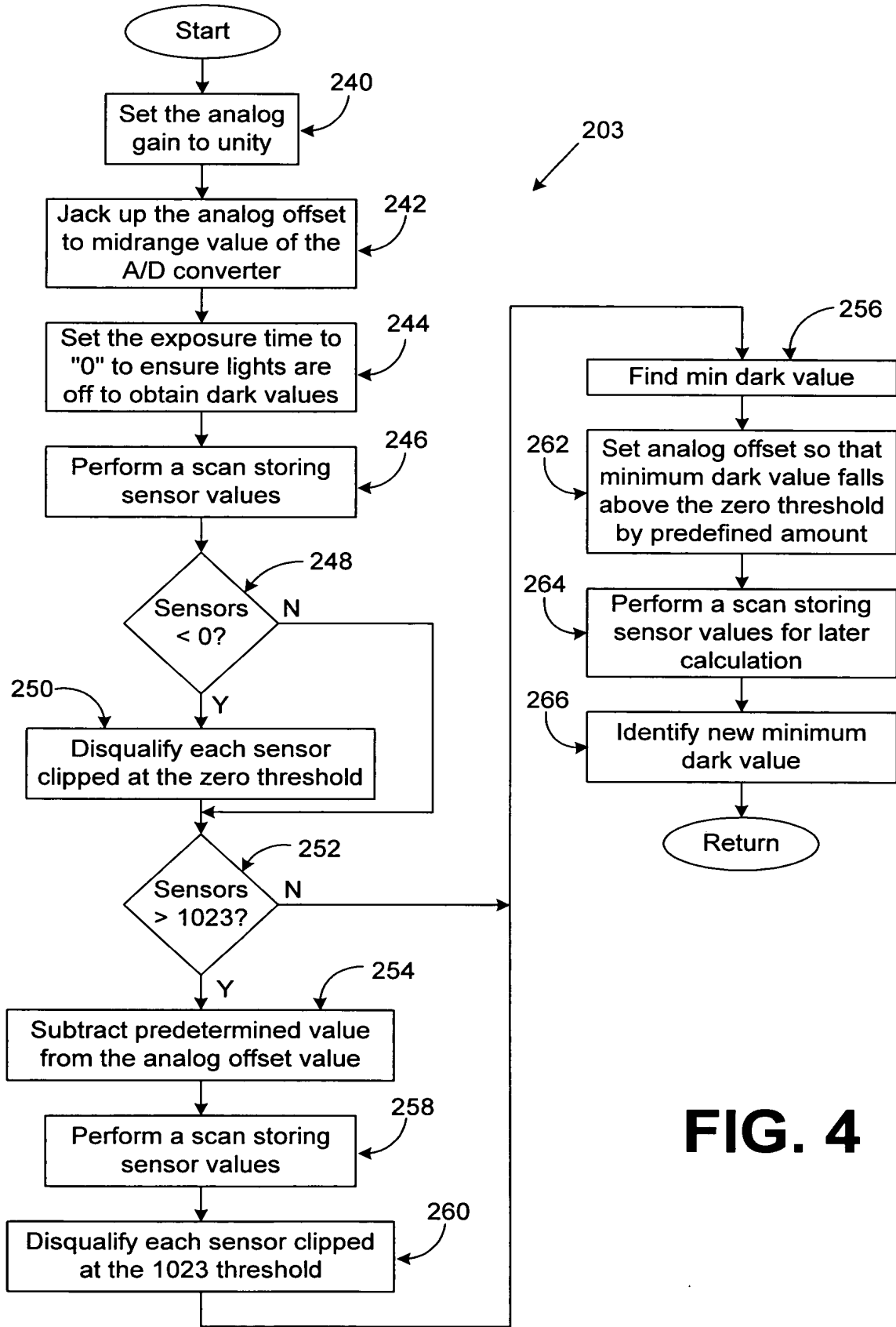

FIG. 4

FIG. 5

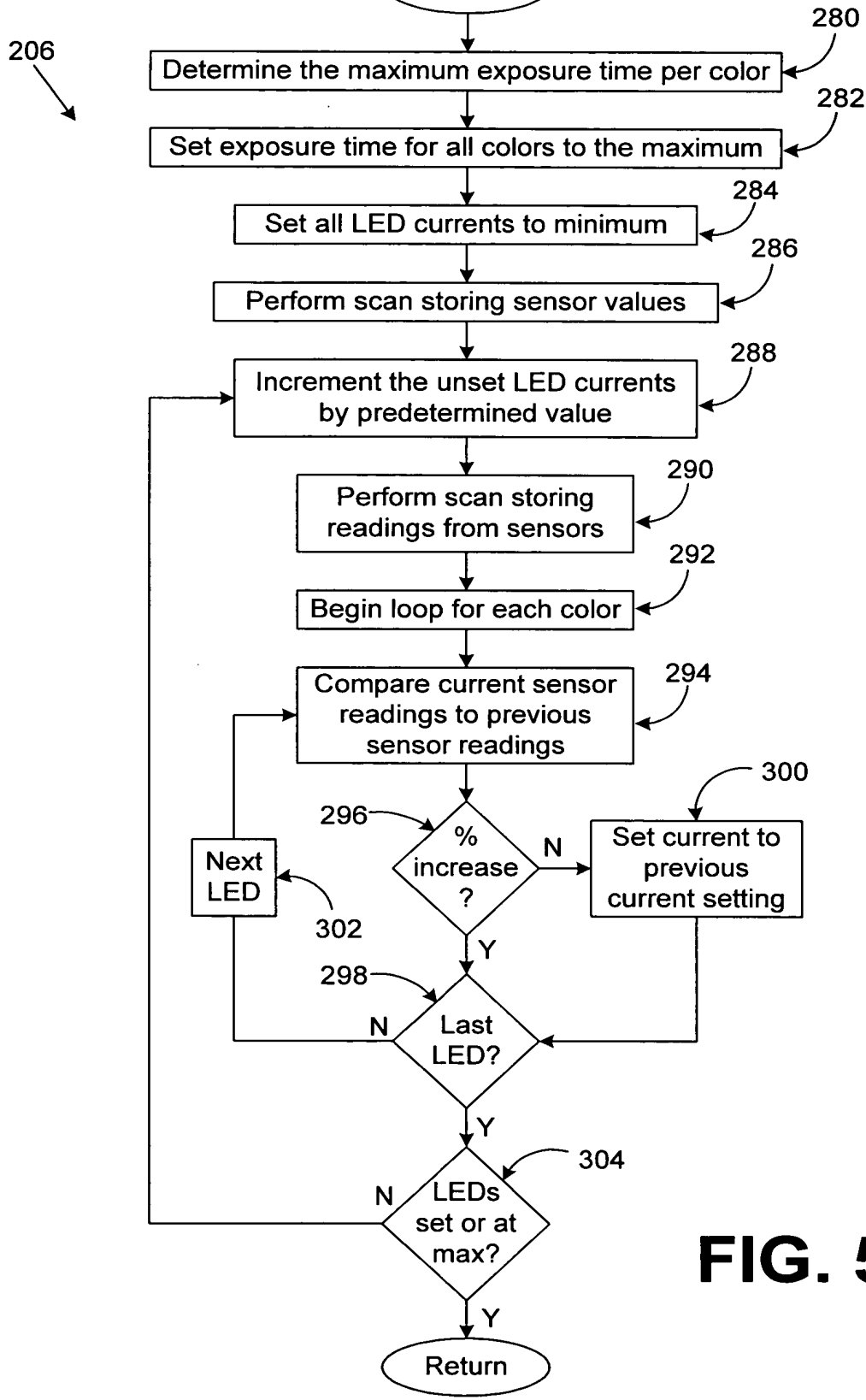

FIG. 5

FOR SO 802550

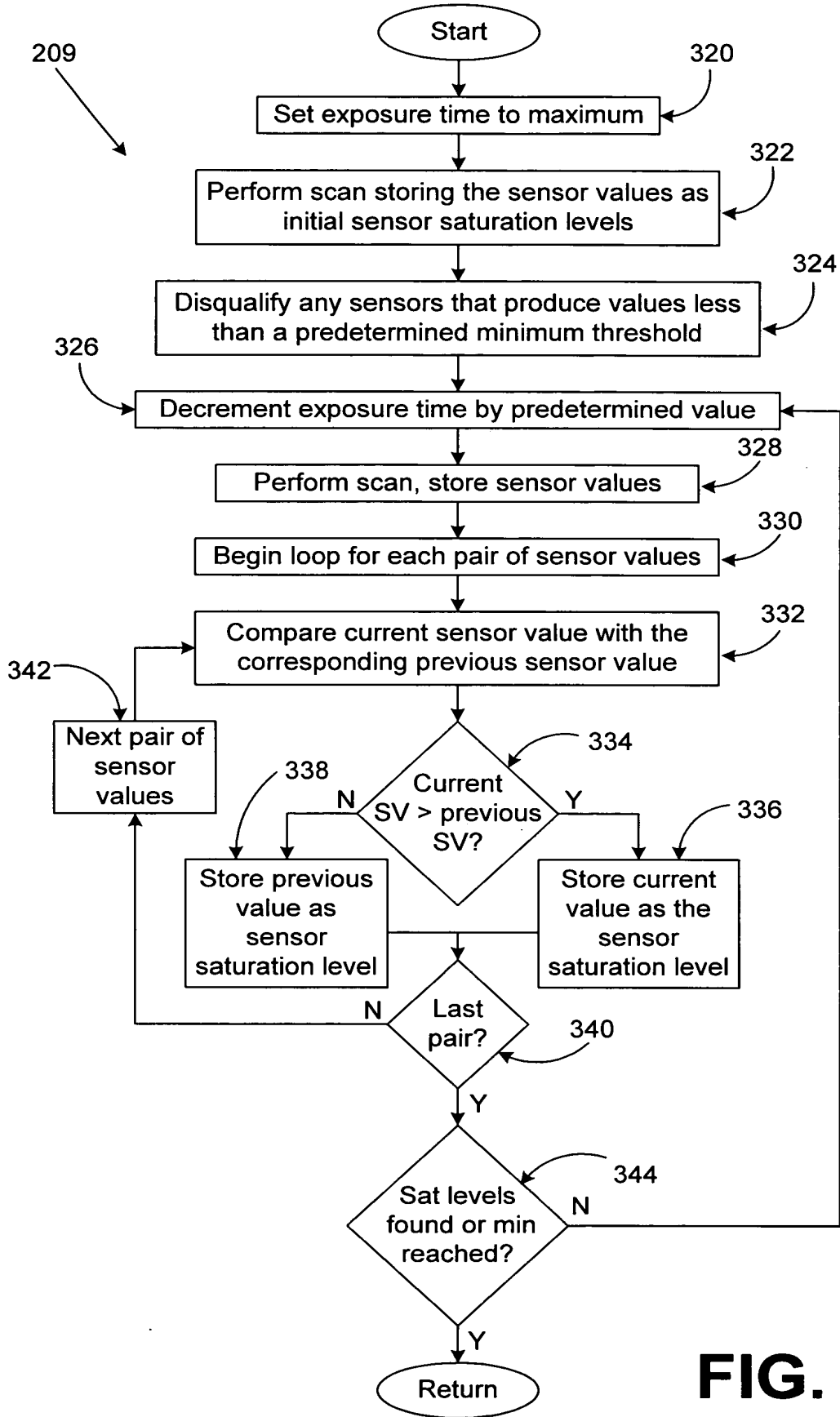

FIG. 6

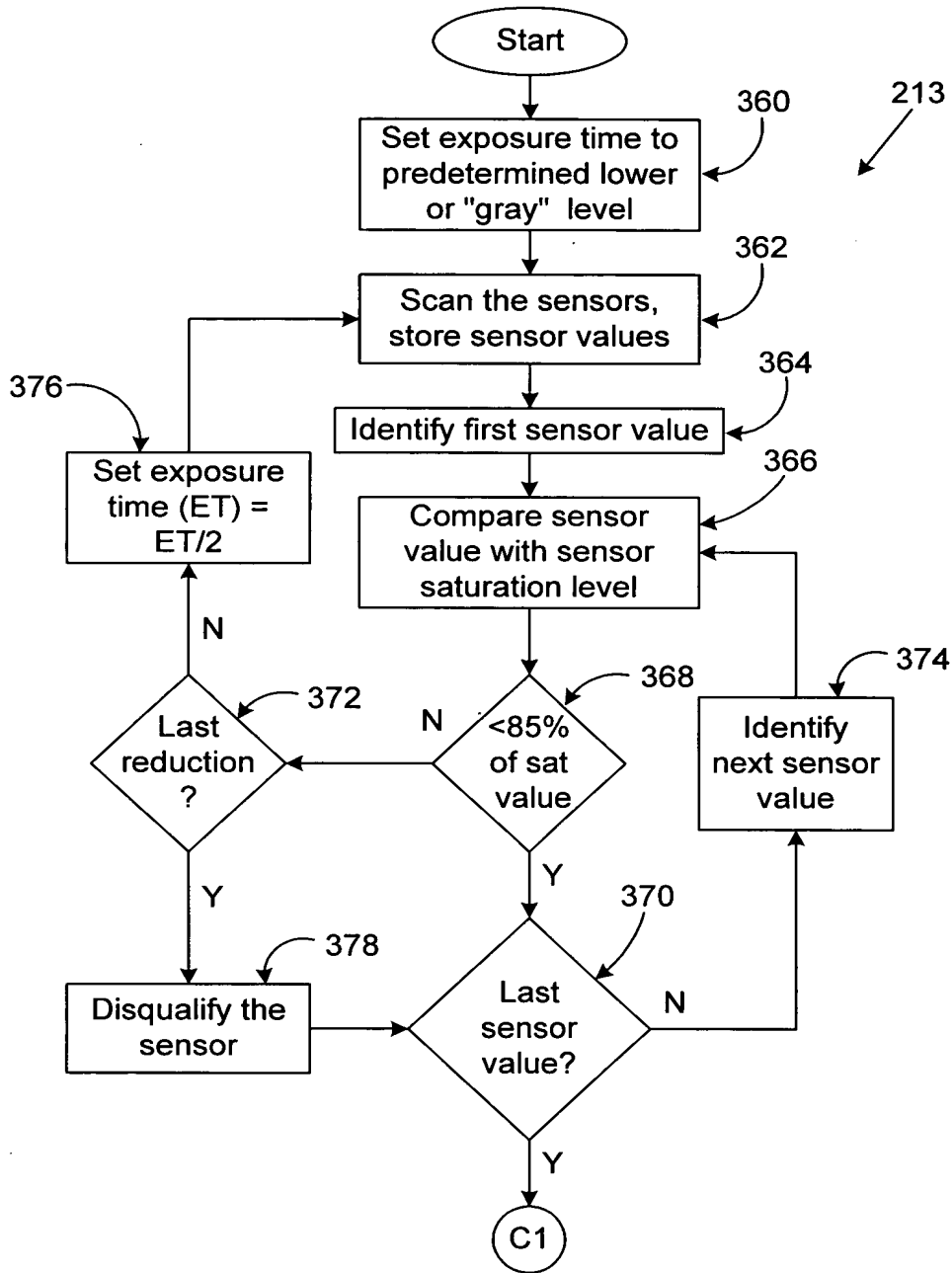

FIG. 7A

TOP SECRET

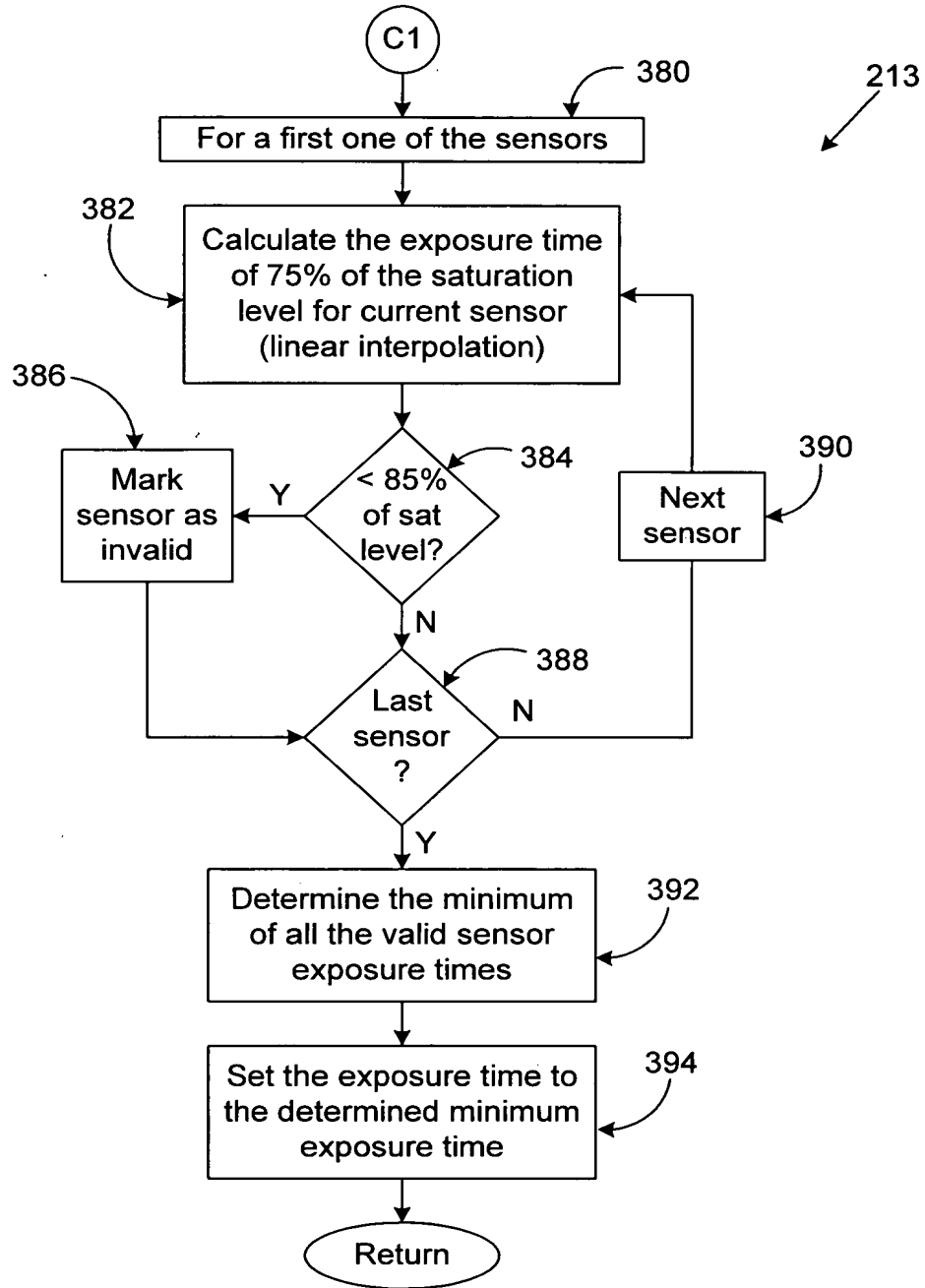

FIG. 7B

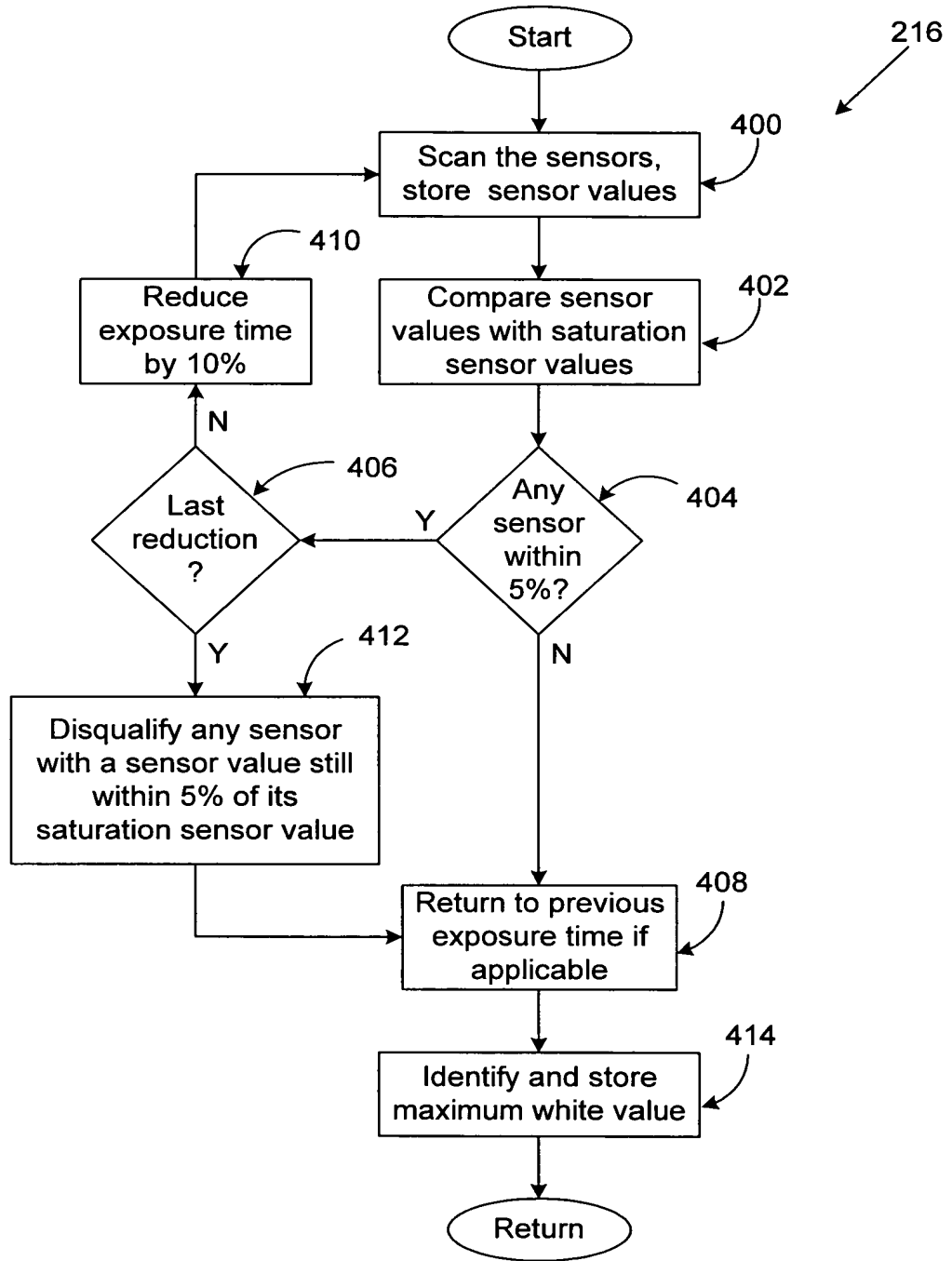

FIG. 8

FIG. 9A

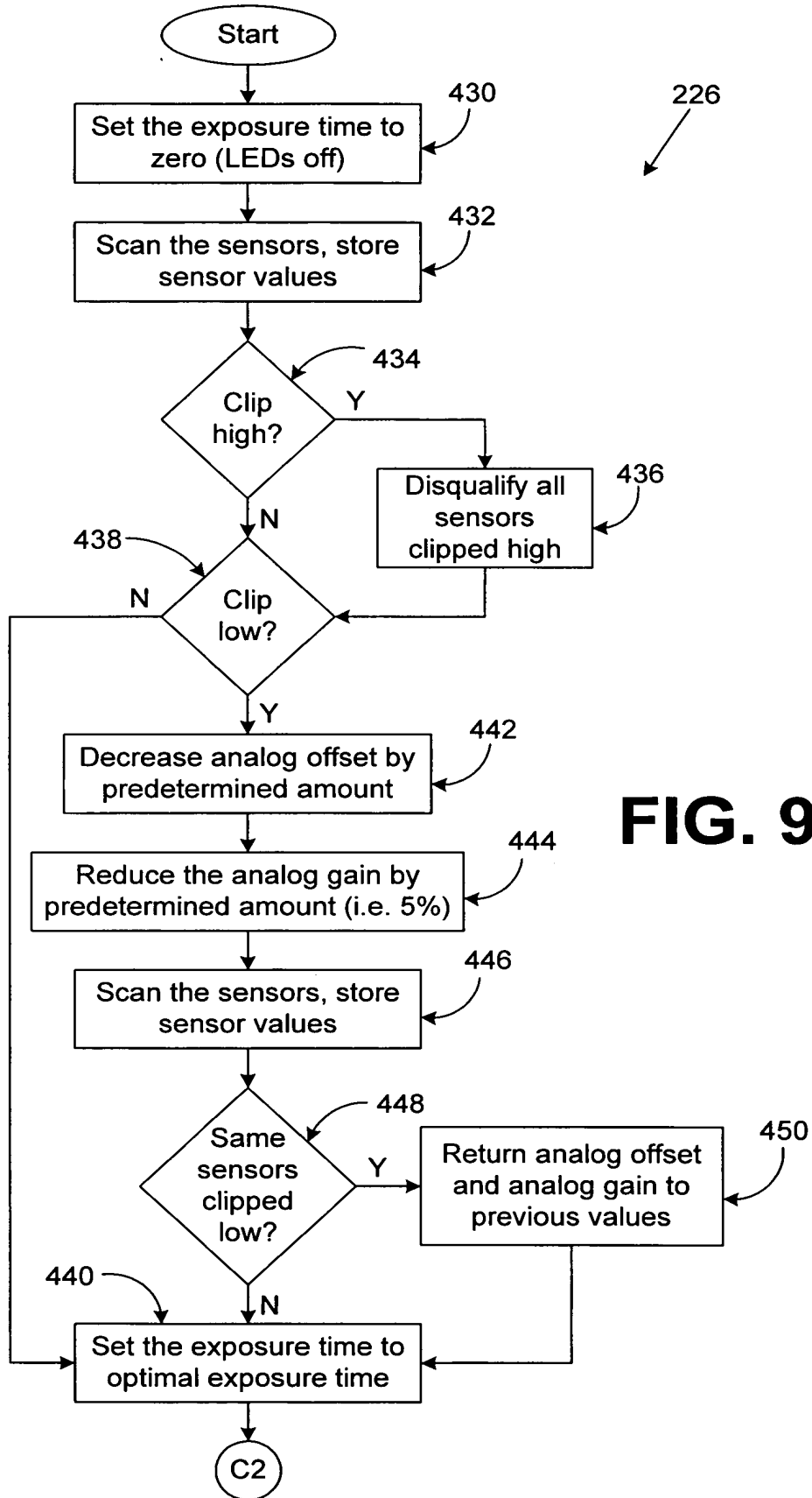

FIG. 9A

FIG. 9B

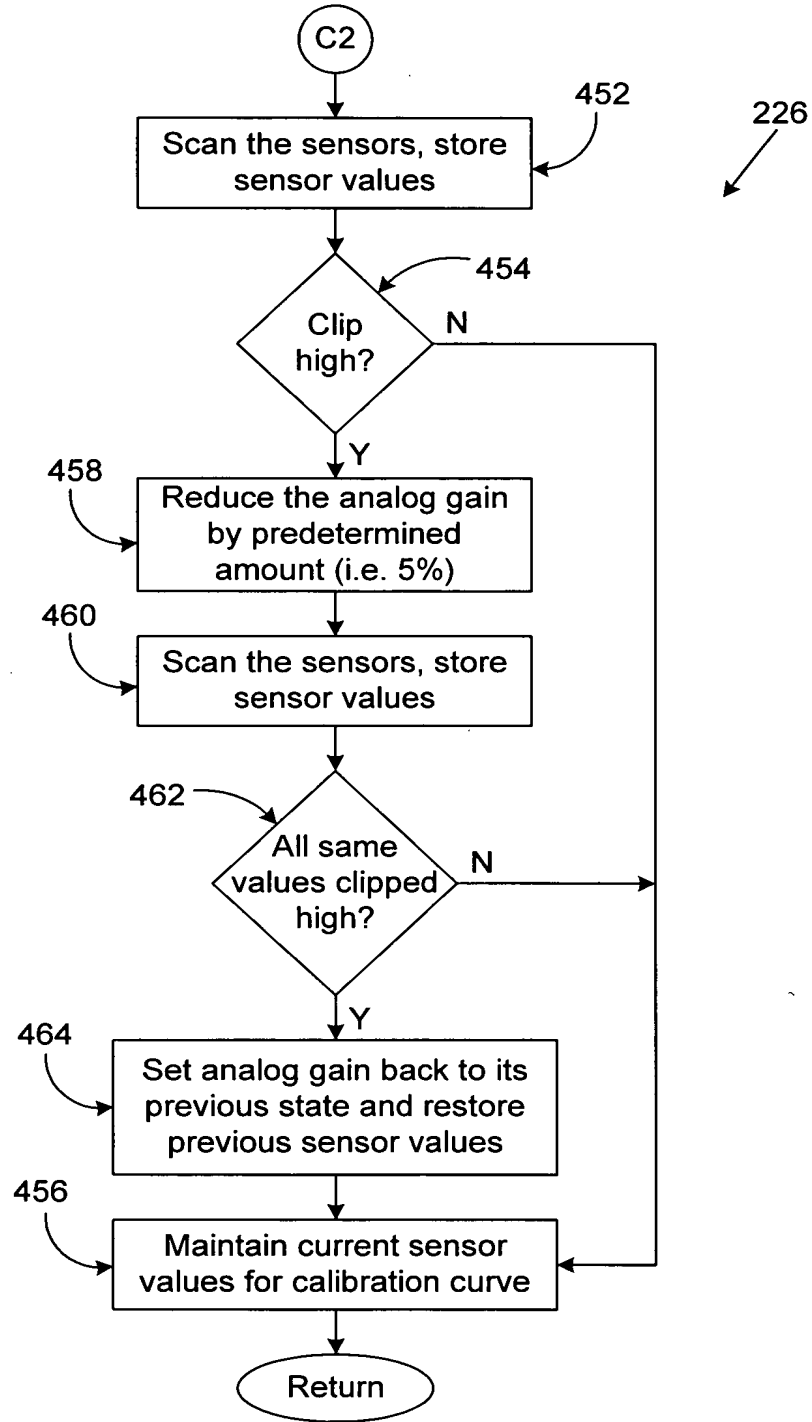

FIG. 9B